



SAND LADEN SLURRY SEPARATION FOR UK FARMS

By
Dr RICHARD COULTON
SAND SEPARATION SYSTEMS LTD

INTRODUCTION

As the sand recovery techniques currently employed in the UK originate from the US, this presentation:

- Looks at the differences between the sand used by UK and US farms
- Explains why the conventional separation systems currently on the market struggle with the separation and recovery of fine sand
- Looks at alternative options for use on UK farms

The principal difference between the types of sand used in UK and US is:

- In the US coarse sand is used (ASTM concreting sand)
- In the UK much finer sand is preferred

The finer grain size makes separation of the sand from the organic matter more challenging

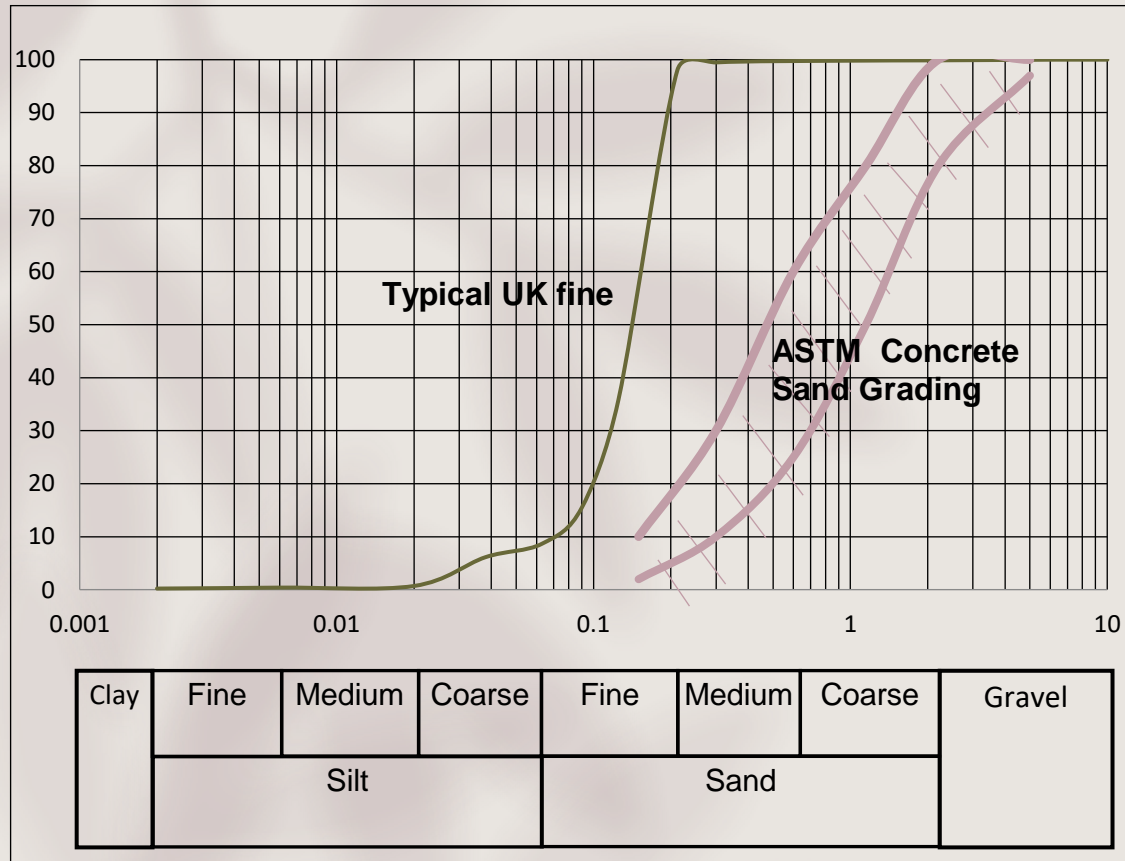

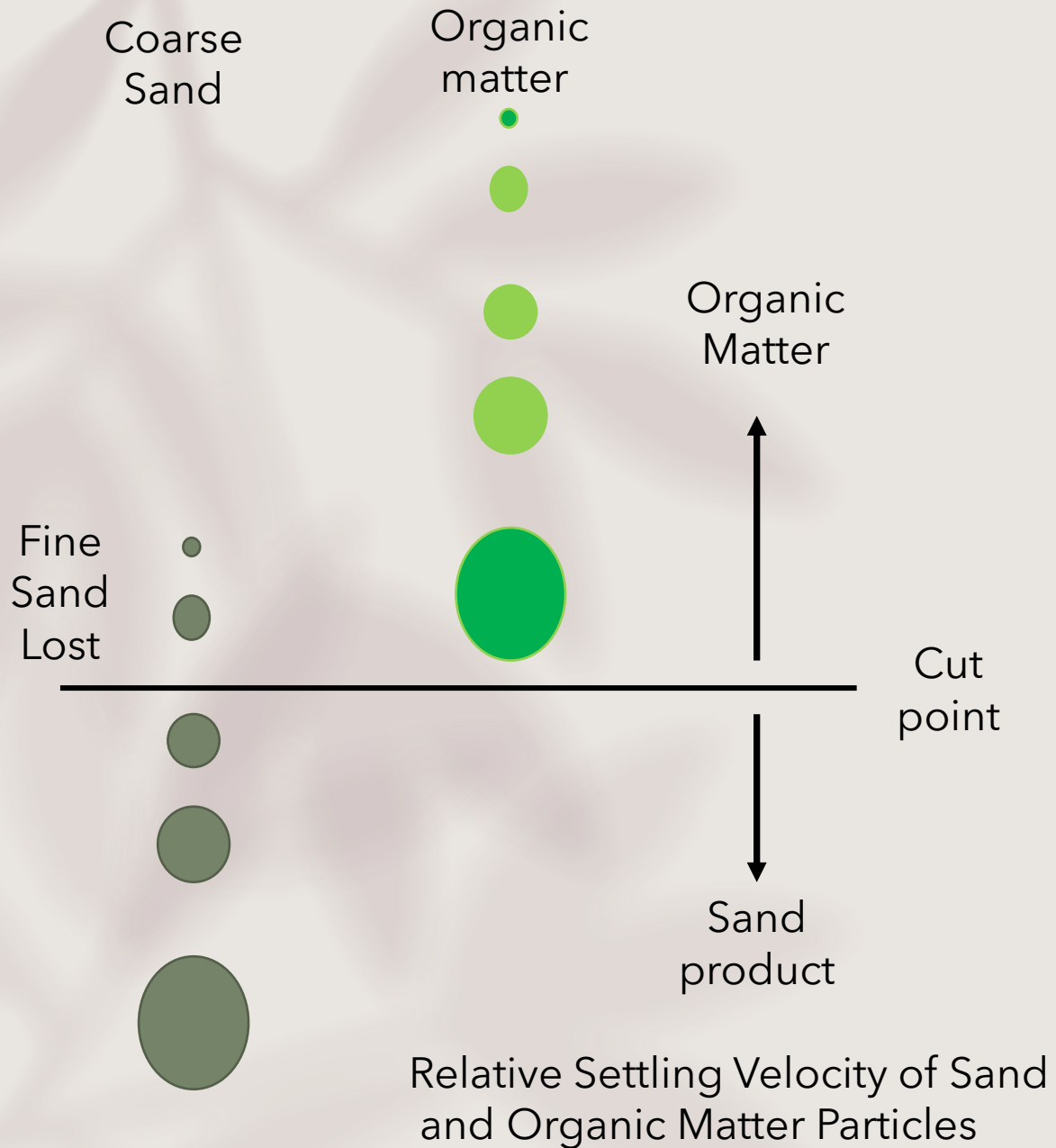

Conventional Separation Systems rely on the Difference in Settling Velocity between the Sand and Organic Particles

Once the slurry has been diluted:

- The larger sand particles settle faster than most of the organic particles
- But the fine sand particles settle at the same rate as the coarse organic particles
- This results in fine sand co-mingled with the organic matter

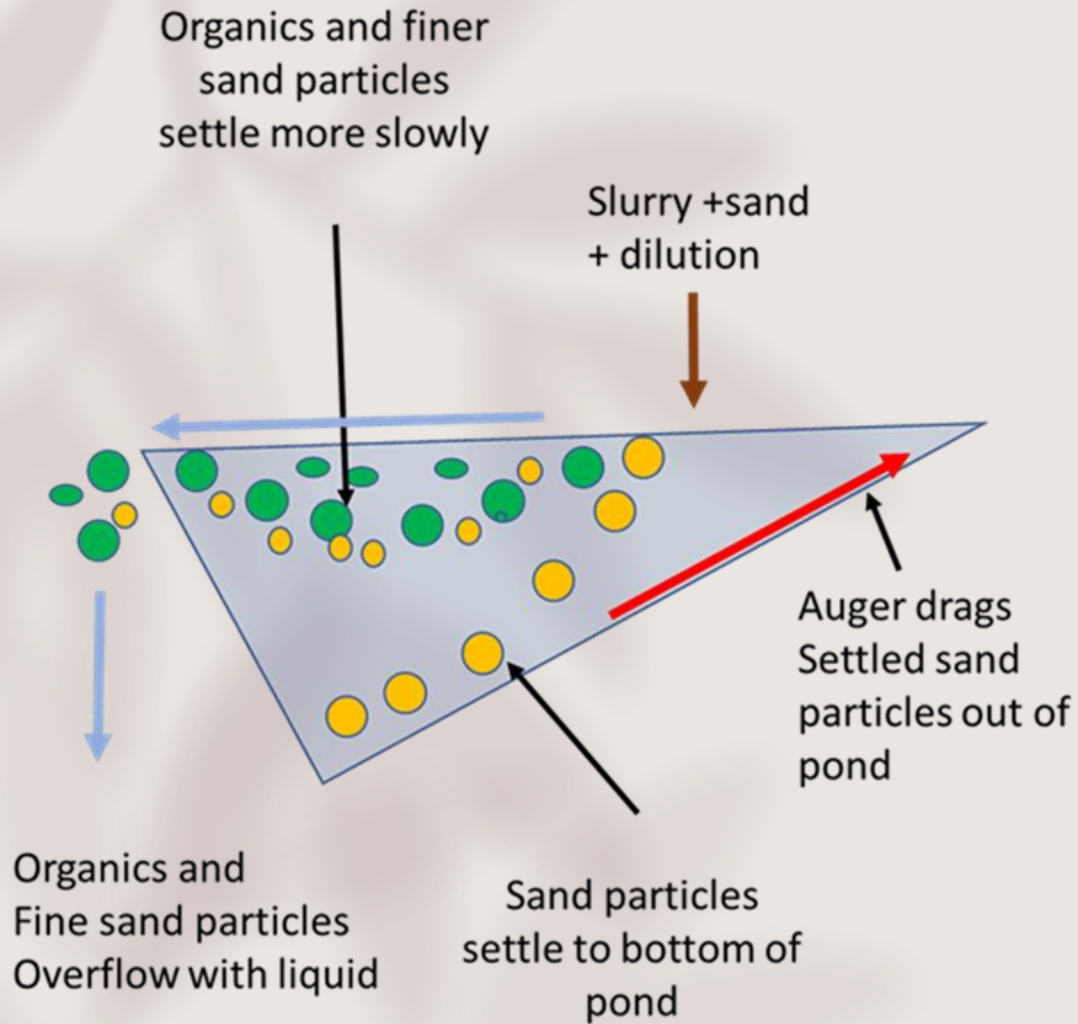

Typically, separation takes place in a pond/pool where:

- The larger rapidly settling sand particles settle to the bottom of the pond and are separately removed.
- The lighter organic particles which settle more slowly are carried away with the slurry liquor
- However, the slower settling finer sand particles are also carried away with the organic matter

What happens if you try to use this approach with Fine Sand?

The attached photograph show what happens when you attempt to separate fine sand from organic matter using the difference in settling velocity

This shows:

- A clean sand layer at the bottom consisting of the coarsest sand particles which settle more rapidly than the organic matter
- A significant amount of fine sand mixed in with the faster settling organic matter particles.
- A clean organic layer at the top comprising organic matter particles that settles more slowly than the finest sand particles.

Overall a high proportion of the sand is lost/co-mingled with organic matter.

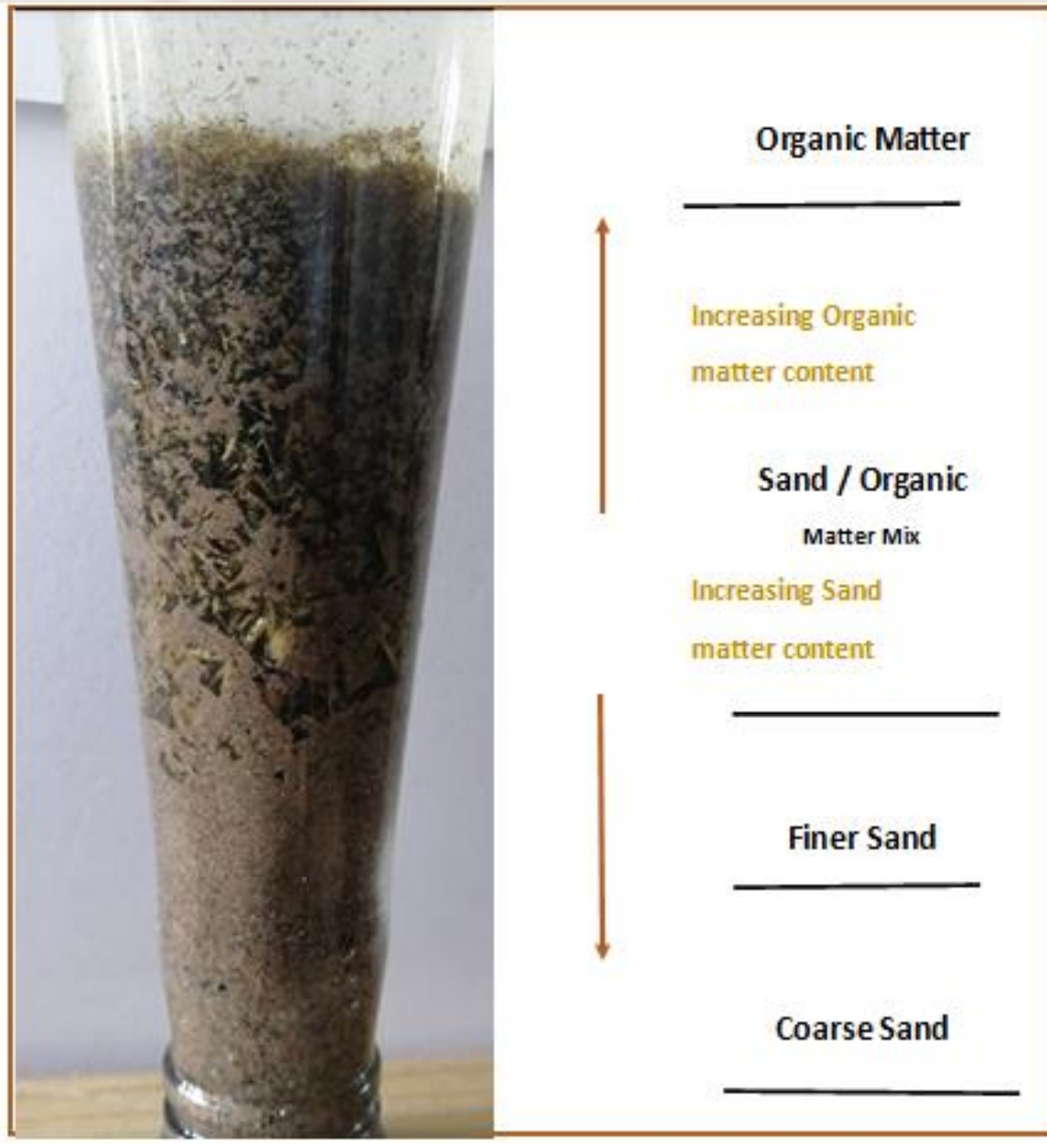

90% of UK Fine Sand will not be recovered by a conventional mechanical separator

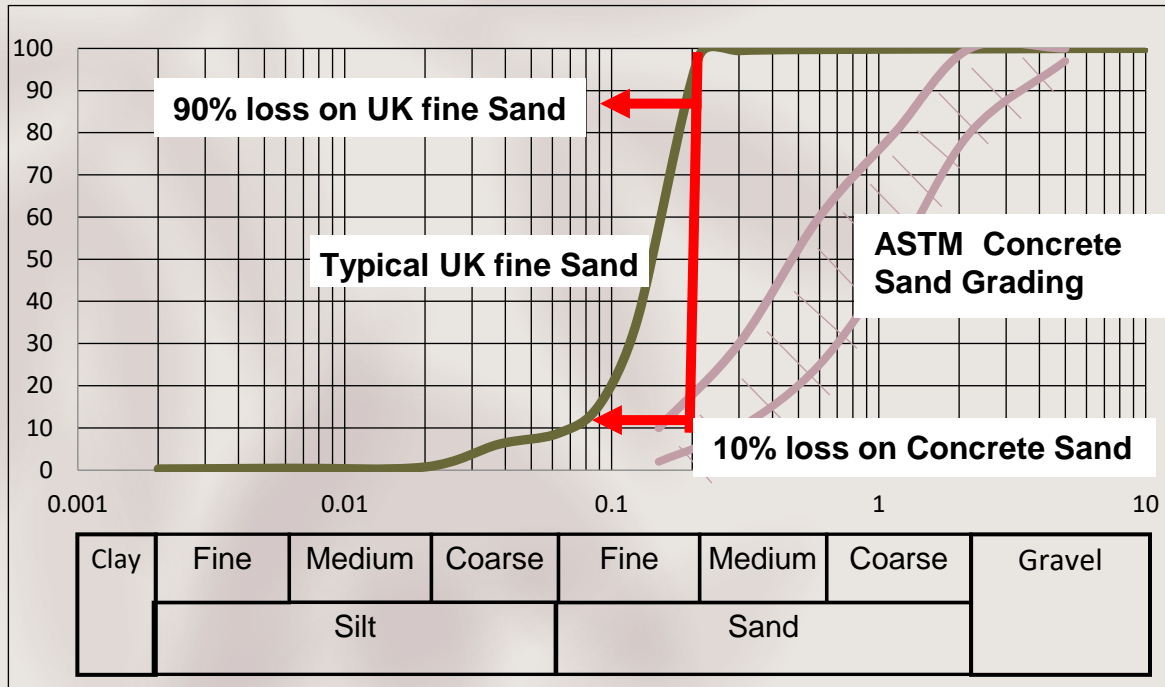

How much sand is recovered by a conventional mechanical separator

- When used on coarse concreting sand
 - A conventional mechanical sand separator recovers 80% to 90% of the coarse sand
 - The remaining sand is either lost or recovered by the secondary processing stage
- When used on the fine sand preferred by UK farmers
 - A conventional mechanical separator only recovers around 10% of the sand
 - The remaining 90% is either lost or has to be recovered by the secondary processing stage.

Feed Material



Sand from primary
separation stage

Comparison of the Feed Material and Sand Recovered by Conventional Mechanical Separator

As shown in the attached photos only the coarse sand particles are recovered and the fine sand is either lost or needs to be recovered using an additional separation stage

So

Why use a conventional mechanical separator unless you intend to use coarse concrete sand as bedding?

If you intend to use the finer sand preferred in the UK an alternative separator is required / more advantageous

What About Sand Lanes?

Sand lanes rely on reducing the flow velocity sufficiently to allow the sand particles to settle, whilst maintaining it sufficiently high to keep the organic matter in suspension

For medium to coarse sand this is between 0.3 to 0.6m/s

For very fine to fine sand this is between 0.18m/s and 0.25m/s

As the flow velocity is reduces more organic matter settles out with the sand and below 0.1m/s everything settles

The velocity is controlled by the sand lane gradient with

- Too steep a gradient resulting in high sand losses
- Too shallow a gradient resulting in co-settlement of organic matter.

To work effectively the difference between the settlement rate of the sand and the organics needs to be as big as possible

Consequently the design of sand lanes for UK farms is a balance between controlling the amount of trapped organics and the amount of fine sand lost

Material Classification	Size range (mm)		Approximate Scour Velocity	
	Min	Max	Maintain	Initiate
Very Coarse Sand	1	2	0.7m/s	2.5
Coarse Sand	0.5	1	0.5m/s	1.7m/s
Medium Sand	0.25	0.5	0.33m/s	1.25m/s
Fine Sand	0.125	0.25	0.25m/s	0.9m/s
Very Fine Sand	0.063	0.125	0.18m/s	0.6m/s
Silt	0.002	0.063	0.03m/s	0.45m/s

A Different Approach is Required for the Recovery of the Fine Sand used by UK Farmers

Separation using the difference in settling velocity is not effective.

However separation based on the difference between sand and organic matter particle density is effective.

Organic matter particle density	1.1 to 1.5
Sand particle density	2.6 to 2.7

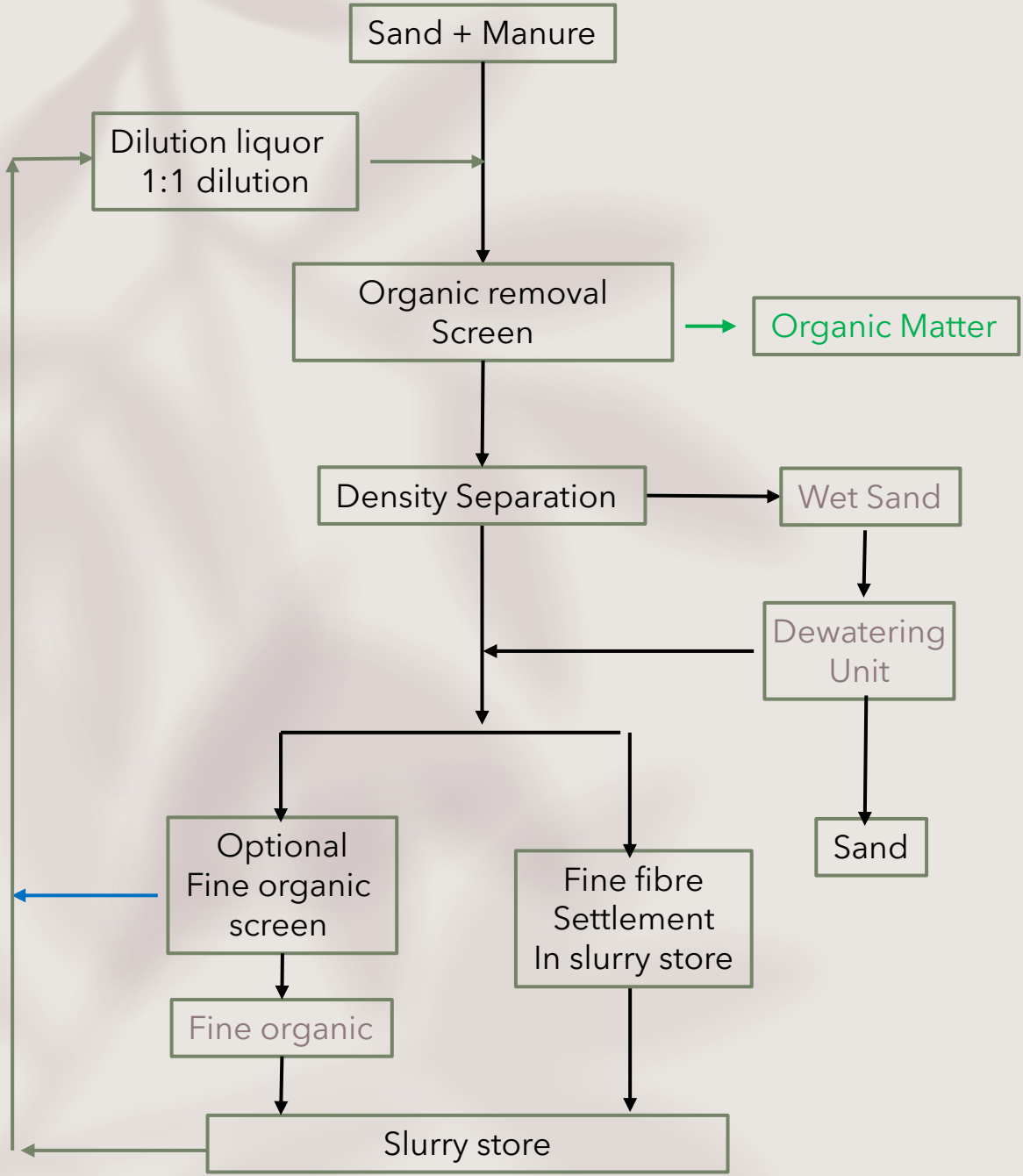

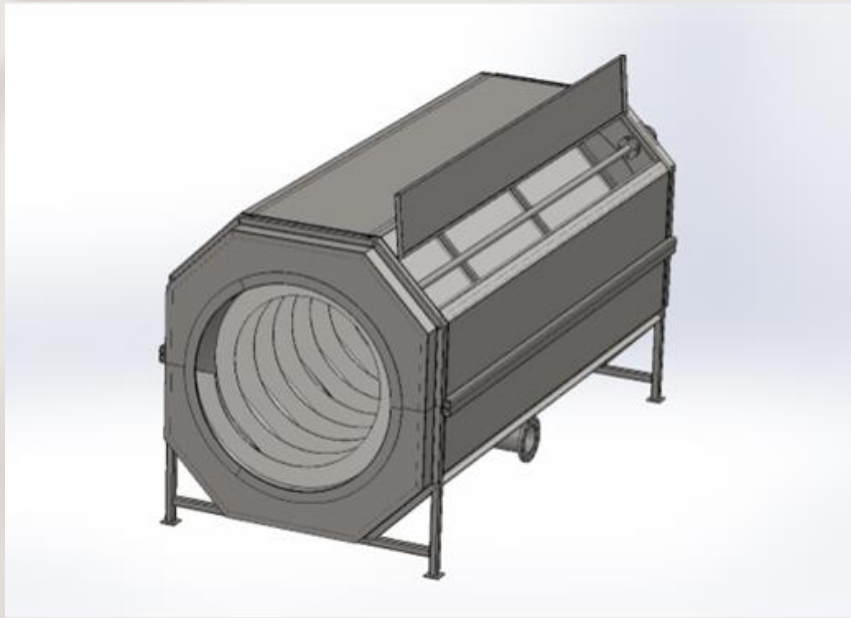

Internal Fed Rotary Drum Screen



External Fed Drum Screen

Recommended Approach For UK Farms

Stage I

- Removal of coarse fibre, stones and other debris (i.e. plastic bags, afterbirth etc.)
- Separation can be achieved using one of the readily available machines using either:
 - Internal fed screen
 - External fed drum screen

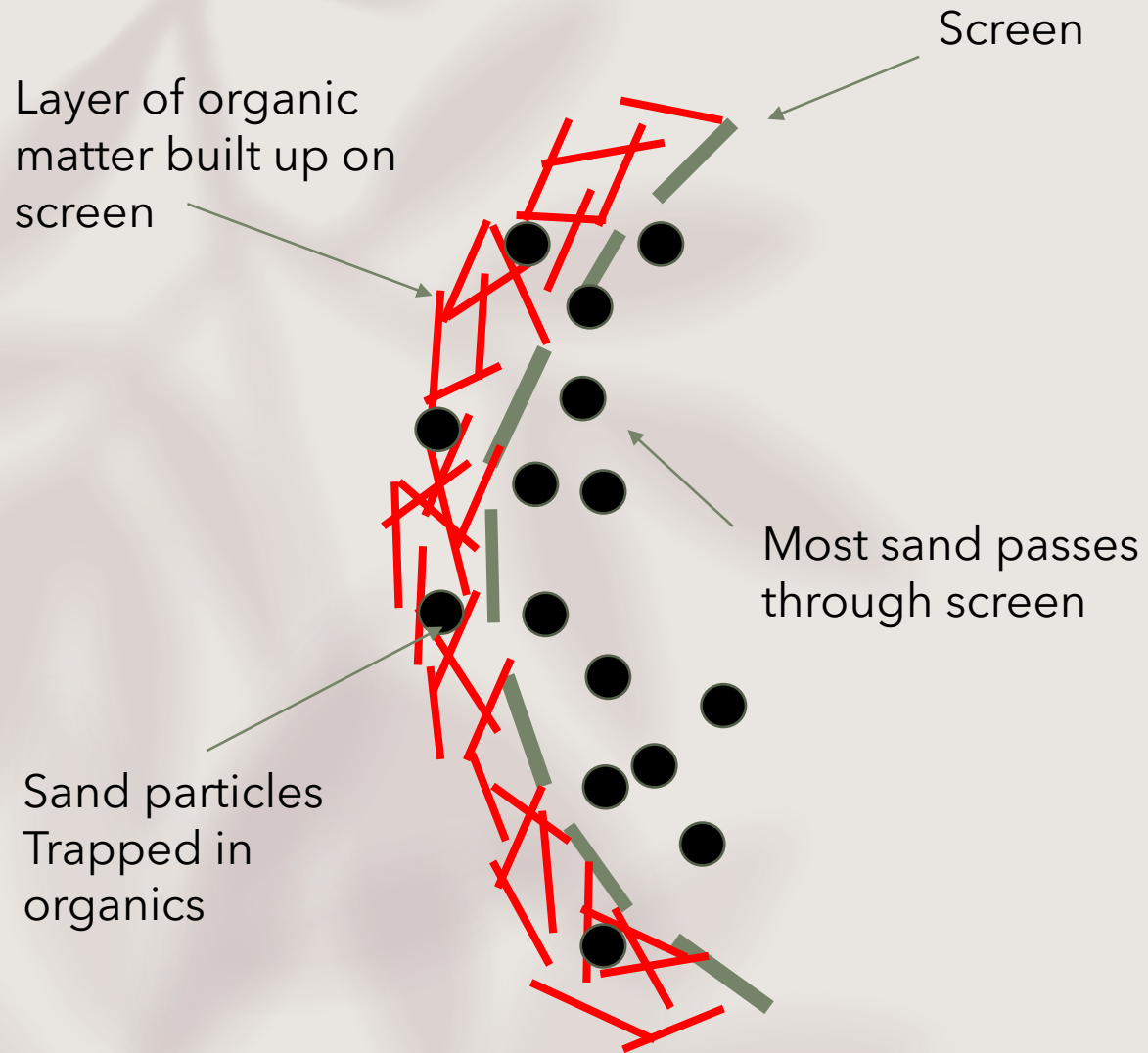

Organic Removal Results In Some Sand Loss

Typically 10% of sand is trapped and lost in the organic matter (depending on how fine the screen is)

As these are trapped in the dry matter they are easy to handle and spread

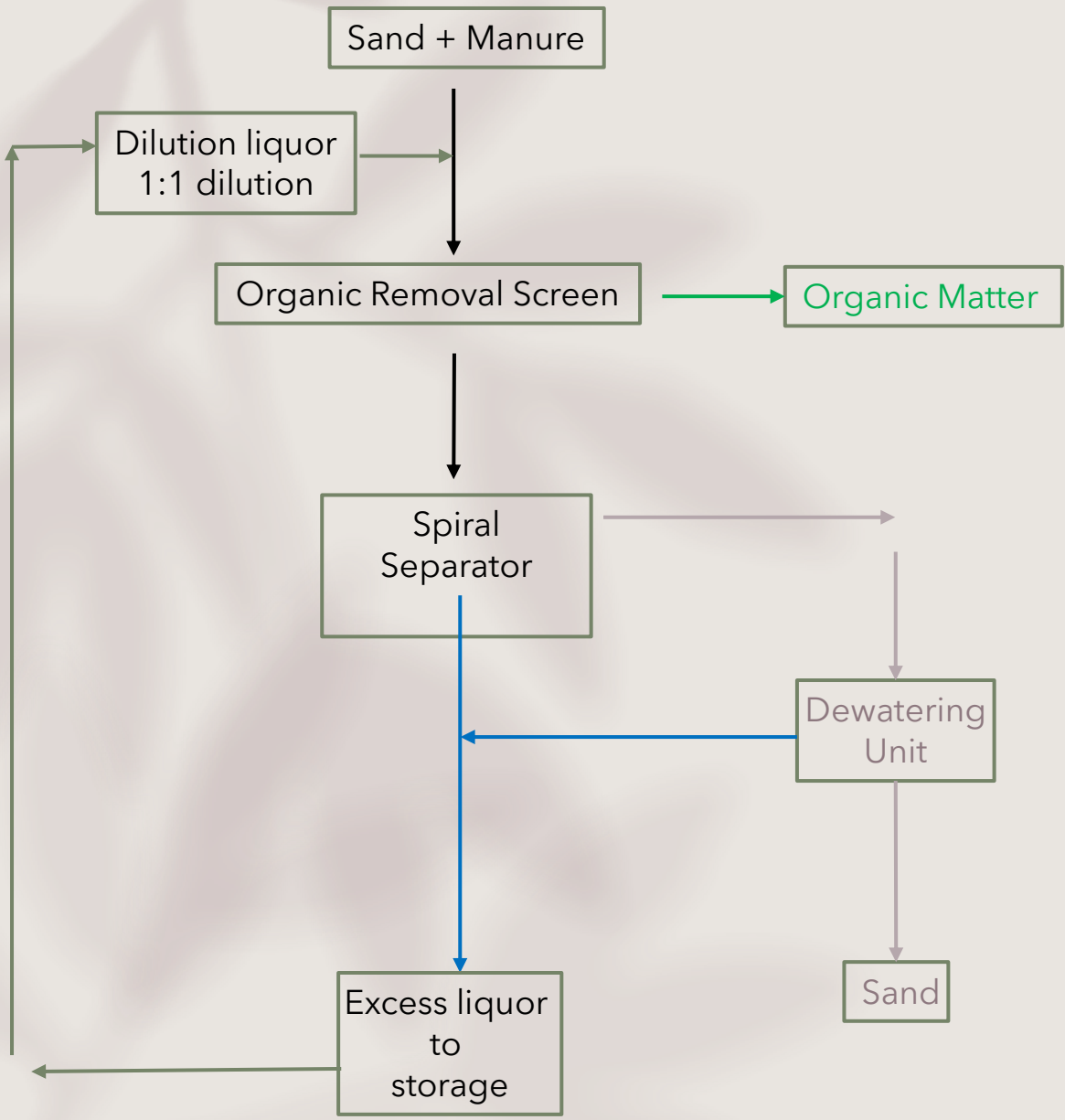

Recommended Approach For UK Farms

STAGE II Density Separation using a Spiral Separator

Advantages

- Compact system requiring minimal space
- Sand recovered on continuous basis
- Sand dewatered using vibrating screen
- Option of rinsing sand with hypo-chloride to reduce bacteria load

Disadvantage

- Pump(s) required to feed separator



Recommended Approach For UK Farms

STAGE II

Spiral Separator

- Process widely used by the minerals industry to separate organic matter from sand
- Simple process requires no moving parts apart from feed pumps for
 - Dilution water
 - Slurry
- Rubber lined quarry pumps used as these are specifically designed to cope with abrasive materials

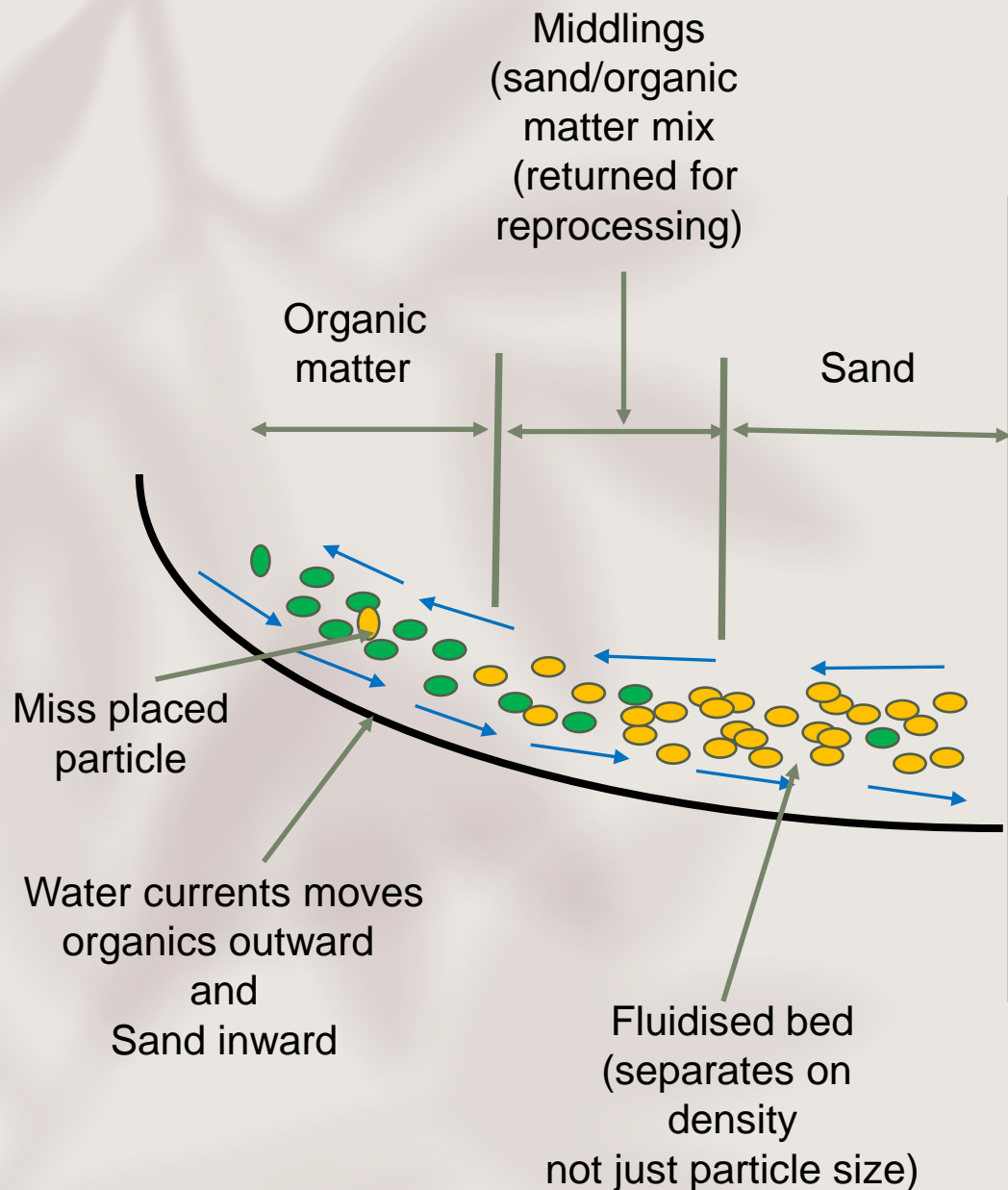

Recommended Approach For UK Farms

STAGE II

Spiral Separator

- Dilute slurry pumped onto the separator using Mineral Industry pump
- Mixture flows down the spiral where a fluidised bed develops allowing separation based on density
- Water currents move:
 - Organic matter to the outside
 - Sand particles to the inside



Recommended Approach For UK Farms

STAGE II

Spiral Separator

- Adjustable gates used to split flow into 3 stream
 - Sand product
 - Middlings –returned to feed
 - Organics



Recommended Approach For UK Farms

Separated Sands and Organic Matter



	250 COWS	500 COWS	1000 COWS
Manure/slurry	64 kg/day/cow		
Sand usage	12 kg/day/cow		
Slurry	E	32t/day	64t/day
Sand	3t/day	6t/day	12t/day
Total Slurry +sand	19t/day	38t/day	76t/day
Dilution water 1:1 minimum	19t/day	38t/day	76t/day
Treatment Requirement	38t/day	76t/day	152t/day
Separator	SBR-8	SBR-8	SBR-16
Raw slurry Capacity	8m ³ /hr	8m ³ /hr	16m ³ /hr
Separation times	2hr/day	5hr/day	5hr/day

Estimated Run Times and Benefits of Sand Separation

Run times are Farm specific but based on the separator capacity vary between 2 and 5 hours/day (excluding start up and switch off times)

The benefits of sand separation include:

- Substantially reduced sand purchase costs (see next slide)
- Reduced wear on slurry handling equipment
- Simplified slurry handling
- Reduced slurry storage requirement (figures of up 32% have been quoted elsewhere)
- Reduced build-up of sludge at the base of the slurry store
- Simplifies slurry store management (particularly important where covers are installed)
- Reduced environmental impact

	250 COWS	500 COWS	1000 COWS
Manure/slurry	64 kg/day/cow		
Sand usage	12 kg/day/cow		
Slurry	16t/day	32t/day	64t/day
Sand	3t/day	6t/day	12t/day
Total Sand usage	1,100t/yr	2,200 t/yr	4,400t/yr
Cost of sand	£20/t		
Recovery	75%		
Recovered sand	825t/yr	1,650t/yr	3,300t/yr
Potential saving in sand purchase	£16,500/yr	£33,000/yr	£66,000/yr
Run time (hours)	1x2hours	1x5hours	2x5hour
Power cost @ 10kW @ £0.30/KWh	£2,200/yr	£5,500/yr	£11,000/yr
Cost Saving (ex handling cost)	£14,300/yr	£27,100/yr	£55,000/yr

Indicative Savings From Recycling (actual saving are farm specific)

Run time includes 1 hour for starting/stopping

Cost saving based solely on price of sand and power consumption by sand separation unit but excludes:

- Feed pump and fibre separator operating cost
- Discounting capital cost
- Cost of handling for reuse

Without sand recovery additional costs would also be incurred due to

- Equipment wear caused by sand abrasion
- Emptying slurry lagoon of sand
- Spreading sand laden manure



Conclusions

- The conventional mechanical separators currently available on the market rely on the difference in settling velocity.
- As result these are not particularly effective in recovering fine sand
- An alternative approach based on particle density rather than settling velocity is required
- Significant savings and environmental benefits can be accrued by the recovery and re-use of sand